

The GENERAL RADIO EXPERIMENTER

VOL. 1 NO. 8

FEBRUARY, 1927



A Study of Coil Resistances at 40 Meters

By L. B. ROOT, Engineering Dept.

When the amateur builds a short wave receiver or wave meter, he demands the lowest loss coil that it is possible to make. There are many good coils now available, with various details of construction, but most of them fall in the classification of an "air wound" coil which is nearly self-supporting. There is no question but that this is a good type, when properly proportioned but it has the disadvantage of being more fragile than a form wound coil and is less adaptable to that very convenient plug-in system of changing from one wave band to another. This brings the experimenter to the question of which he shall choose—lowest loss, or merely low loss, and good mechanical construction. The following measurements at 40 meters indicate some of the causes of losses in coils, and show that their source is frequently other than is supposed.

The diagram in Fig. 1 shows the method of measurement used in these tests. This is the General Radio type 353 Radio Frequency Measuring Set.

The pickup coil consists of only a few turns of wire to absorb energy from the source and feed the balance of the circuit. The coil "D" is a drop coil to by-pass the radio frequency around the high impedance

of the crystal detector and galvanometer circuit, and provide a voltage drop to operate the galvanometer.

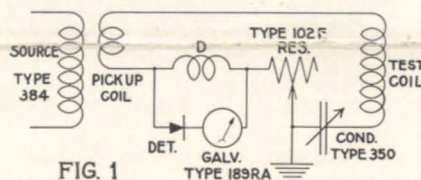

FIG. 1

In operation the circuit is tuned to resonance with the resistance box set at zero, carefully noting the maximum galvanometer reading. Then the test coil is short-circuited and the circuit reset to resonance by increasing the capacitance of the standard condenser. The galvanometer deflection is then much greater than before, because the resistance of the test coil has been removed. Therefore, resistance is added to the circuit until the deflection at resonance is the same as before. This resistance is equal to that of the coil at the frequency of measurement.

The assumption of this method is that the resistance of the standard

condenser does not change with setting. Obviously, this is not true, for it is known to decrease as the capacitance is increased. The condenser used is especially designed for this work, with the

smallest possible amount of insulation, and that is placed in a weak electrostatic field. The conduction losses are very low. The circuit is sensitive enough to detect a change of 1/50 of an ohm, but when two of these condensers are connected in parallel, no change of resistance can be noted. It is, therefore, safe to neglect the resistance of the condenser, and assume that there is no change with setting.

In order to determine the proper size of wire to use for 40 meter coils, a single Type 277 moulded bakelite form was wound with various sizes of wire from No. 8 to No. 26. Each winding consisted of ten turns, and, as the length and diameter were constant, they were of essentially the same inductance. Length of coil, $1\frac{7}{8}$ "; diameter, $2\frac{3}{4}$ ". This was chosen as a typical coil, for it had an inductance of about 7 microhenries, and required about 50 mmf to tune to 40 meters, a very usual condition in a receiver.

Measurements of this series of coils gave the curve shown in Fig. 2.

It is evident from this curve that



IET LABS, INC in the GenRad tradition

534 Main Street, Westbury, NY 11590

www.ietlabs.com

TEL: (516) 334-5959 • (800) 899-8438 • FAX: (516) 334-5988

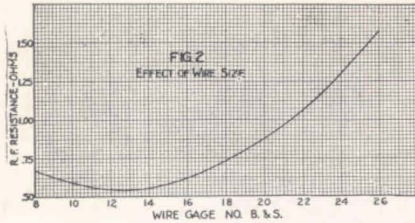

there is an optimum size of wire which is not critical, but should be approached for minimum resistance. Curves taken similarly at other frequencies indicate that there is an optimum size for each wavelength band, and that the lower the frequency, the smaller the wire.

The use of collodion, shellac, or other good binders had no appreciable effect.

In order to test the effect of coil form a coil form was wound in the usual manner, and a strip of bond paper cemented to the circumference of the wire with collodion. When dry, it was possible to slip out the form without disturbing the wire. Measurements on this coil gave the following:

Resistance of coil with form .8 ohms
Resistance of coil without form .6 ohms
Gain 25%
Inductance 7.5 microhenries

But it is efficiency in which we are interested, and a reduction of resistance is not indicative of the true gain. It is power factor which is to be considered.

$$\text{Reactance} = 2\pi fL = 6.28 \times 7.5 \times 10^6 \times 7.5 \times 10^{-6} = 353 \text{ ohms.}$$

$$\text{Power factor} = \frac{R}{X} = \frac{.8}{353} = .23\% \text{ with form.}$$

$$\text{Power factor} = \frac{.6}{353} = .17\% \text{ without form.}$$

From this it is evident that the power factors differ by about .06%—a very doubtful gain when elimination of the form means a less rugged coil, more difficult to construct. The change of distributed capacity was too small to measure.

Some rather surprising results were obtained by placing metal in the field of the coil. The same coil was used in all the tests, having a resistance of .7 ohms, and an inductance of 7.5 microhenries. P.F. was .2%.

A strip of .010" x 1 1/2" copper 4" long was placed along the axis and inside of the coil. Power factor rose to .23%, an increase of .03%.

A sheet of 1/4" aluminum placed successively nearer the side of the coil had no readable effect until it

actually touched the insulation, when the power factor became .21%. When placed flat against the end of the coil, the change was very slight.

A strip of .010" x 1 1/2" copper was placed around the circumference of the coil, with about 1/2" air space. When the loop was not closed to make a short-circuited turn, the power factor was .22%, but when closed it became .26%.

As an extreme case, a copper can was made to enclose the coil entirely, leaving about 1/2" air space all around. The power factor went up to .27% in this case.

Power factor is mentioned in all of these tests rather than resistance, as a true indication of the change. In most instances, the inductance of the coil was reduced somewhat, accompanied by an increase of radio frequency resistance.

Six different coils were wound to practically the same inductance, on

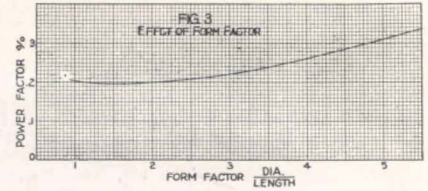

the same diameter form, but with different winding lengths, and consequently some variations in the number of turns. Inductances averaged 7 microhenries. The curve of Fig. 3 shows the results.

The object of these experiments was not to prove that bad coils are good, nor to discourage the construction of really low loss coils, but to find the causes of inefficiency, and what practical means could be taken to avoid them.

It is very evident that most of the losses come from the conductor itself, and while form and nearby metal objects do contribute, their effect is relatively small, and if (Continued on page 3)

Mass Wavemeter Calibration

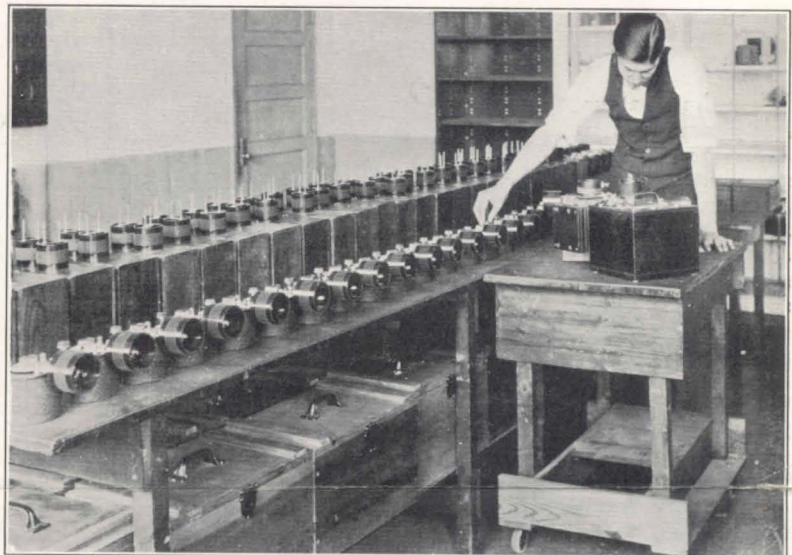

We are continually hearing of the use of modern efficiency methods in the production of everything from fans to flivvers. Above is illustrated an example of their application to the laboratory. Since each Type 358 Wavemeter has an individual calibration chart, the calibration of these units becomes somewhat of a problem due to large numbers manufactured as a consequence of the popularity of this wavemeter. Much time is saved by the method shown above. A number of wavemeters are set up in a long row. A radio frequency oscillator and a standard wavemeter are placed on a truck somewhat resembling a tea wagon, and the oscillator set to the proper frequency for the first calibration point, this being checked by the standard wavemeter.

that the oscillator is coupled to the first wavemeter in line and the wavemeter condenser rotated until resonance is indicated. The dial reading for this frequency is marked down, and the truck wheeled down the line, repeating the process for each wavemeter. The oscillator is kept exactly at the proper frequency by constant reference to the standard wavemeter. The oscillator is set to another frequency, and each of the wavemeters in turn adjusted to resonance. In this manner the data for a number of calibration charts is gathered with a minimum of manipulation of apparatus. When data has been obtained in this manner for points on each coil, it is plotted and the charts mounted and boxed with the meters for shipment.





A New Capacity Bridge

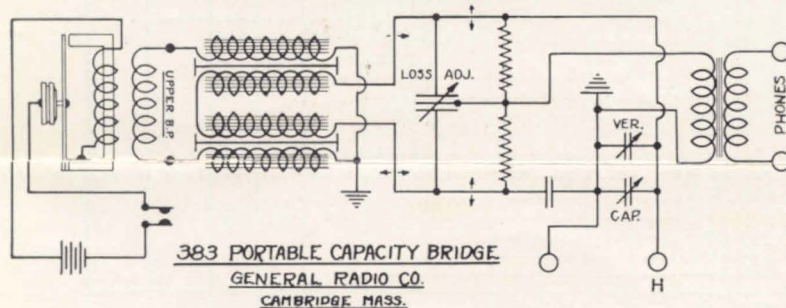

The measurement of small capacities is of great importance in several branches of radio work. The inter-electrode (grid-filament, plate-filament, and grid-plate) capacities of vacuum tubes are of particular importance in the design of delicately adjusted receivers. For this reason, the measurement of these quantities is of great importance both to tube and to receiver manufacturers. The very small quantities involved (about 5 micromicrofarads) render the usual type of bridge measurement not very satisfactory for this use. Among the recently developed laboratory instruments of the General Radio Company is the Type 383 Portable Capacity Bridge, particularly designed for this type of work.

A conventional type of bridge circuit is used, consisting of two resistance and two capacity arms. It is actuated by a self-contained microphone hummer supplied from a 4½-volt dry battery. The output from the hummer, of about 800 cycles frequency, is fed through a transformer to the bridge circuit. The transformer has shielding between its primary and secondary, and is in addition wound in two sections so as to reduce capacity effects. The phones are supplied from another transformer, its primary connected across the bridge, the secondary brought to the lower terminals in the photograph. Three adjustments appear on the bridge panel, marked LOSS ADJ., ZERO ADJ., and CAPACITY. These correspond to the condensers labelled LOSS ADJ., VER., and CAP., respectively in the diagram. The LOSS ADJ. condenser, shunted across the resistance arms of the bridge, compensates

for the variation from zero of the power factor of the unknown capacity. This adjustment is not calibrated as it is not intended for use as a means of measuring power factor. It is intended merely to compensate for loss current in the condenser arm which might otherwise render a balance of the bridge impossible. The zero adjust condenser is included across the balancing condenser and the unknown in order to balance out stray capacities of leads, sockets, etc. As the ratio arms and standard condenser are fixed, the total capacity in the fourth arm of the bridge, which includes the unknown with its leads, the zero adjusting and the measuring condenser must be constant for balance. In making measurements the leads, sockets, or other apparatus associated are connected to the terminals and the capacity of the ZERO ADJ. condenser reduced sufficiently to balance the bridge with the CAPACITY condenser set at maximum capacity. The dial on this condenser is set to read 180 degrees out of phase with the capacity, i.e., the dial is set at 0 for maximum capacity.

The unknown capacity is then connected and the condenser marked CAPACITY rotated (reducing its capacity) until the bridge is again balanced. The LOSS ADJ. condenser is adjusted as required in each case. The capacity of the unknown condenser is obtained by multiplying the reading of the measuring condenser by a factor appearing on the dial.

A very convenient accessory in making measurements on the inter-electrode capacities of vacuum tubes is the socket shown in the fore-

ground. This socket is equipped with three plugs so spaced as to fit the binding posts of the bridge, and connected to grid, plate, and filament. In measuring the tube capacities, this socket is plugged in and the bridge balanced for zero. The tube is then placed in the socket and its capacities measured directly.

Readings can be made to about one-half division on a one hundred-division scale with ear-phones, or somewhat more accurately if an amplifier and vacuum tube voltmeter are used.

The new Capacity Bridge is made in two models. One, with a range extending to thirty micromicrofarads, is designed for the measurement of small capacities. Another model, its range extending to 600 micromicrofarads, is particularly useful in matching condenser units for use in single control setups. The accuracy of the instrument makes it very useful for this purpose, as it will show up smaller differences between such units than are permissible in the receiver. Its simplicity in comparison with the quartz-controlled oscillators and other expedients resorted to for condenser matching recommends it strongly.

A very useful adjunct to the capacity bridge is a two-stage amplifier. A vacuum tube voltmeter can then be used to detect balance and a somewhat greater accuracy attained than is possible with earphones. Another advantage of the voltmeter is that it permits tolerance limits to be marked on the dial of the voltmeter, a useful practice in factory inspection work.

Coil Resistance at 40 Meters

(Continued from page 2)

something else must be sacrificed, the gain may not be worth while.

Finally, it may be summed up that in designing a coil of a given inductance for the forty meter band, it is well to

1. Use about No. 12 to No. 14 wire.

(diam.)

2. Keep the form factor

(length)

around 1 to 2.5.

3. Use a form if desired.

4. Use plugs and jacks if desired.

5. Use any good "dope" as a binder.

6. Use any reasonable amount of shielding where advantageous.

For all practical purposes the coil will be of low losses, mechanically strong, convenient to use, and, if wound on a good form, will retain its calibration indefinitely. And these advantages are obtained with but slight and immaterial sacrifice of efficiency.



THE GENERAL RADIO EXPERIMENTER

Vacuum Tube Data Table

Correct to February 1, 1927

TYPE	FILAMENT		B VOLTS	C VOLTS	PLATE CURRENT MILS	PLATE IMP. OHMS	MUT. COND. M.MHOS	AMP. FACTOR	PEAK EMISSION MBS.	OUTPUT MILLIWATTS		CAPACITY COLD M.M.F.	MAX. DIA. INCHES	MAX. HEIGHT INCHES
	VOLTS	AMPS								UNDIST.	AS OSC.			
WD 11	1.1	.25	22	0	4	22000	260	6	25		6			
WD 12			45	-1.5	1.1	18000	345	6.2			30	G-F 6	1 1/16"	4 3/16"
CX 11			67	-3	1.8	17000	365	6.2			85	G-P 5.5		
CX 12			90	-4.5	2.6	16000	390	6.2			150	P-F 7.5		
\$2.50														
UX 199	3.3	.063	22	0	4	26000	230	5.9	9		6			
CX 199			45	-1.5	1	19500	320	6.25			30	G-F 3.6		
UV 199			67	-3	1.7	16500	380	6.25			80	G-P 3.5		
CV 199			90	-4.5	2.5	15000	415	6.25			150	P-F 4.5	1 1/16"	3 1/2"
			135											
			90	-7.5	1.3	19000	330	6.25			15			
\$2.25														
UX 120	3.3	.130	22	0	1	10000	320	3.2	24		16	G-F 4.5		
CX 120			45	4	2	8500	390	3.3			60	G-P 5.4		
			67	9	3	8000	410	3.3			140	P-F 4.4	1 3/16"	4 1/8"
			90	16.5	3.2	7700	430	3.3			200			
			135	22.5	7	6600	500	3.3			650			
			135	27	5.5	7500	430	3.2			110			
\$2.50														
UX 201A	5	.25	22	0	.5	26000	325	8.4	45		8	G-F 5.8		
			45	1.5	.9	18500	460	8.4			28	G-P 10.1		
			67	3	1.5	14000	600	8.4			70	P-F 6.1	1 13/16"	4 11/16"
			90	4.5	2	12000	710	8.5			130			
			135	9	2.5	11000	775	8.5			50			
			180	13	3	9000	940	8.5			230			
\$2.00														
UX 112	5	.5	22	0	1.1	14500	550	8	150		17	G-F 9		
			45									G-P 11	1 13/16"	4 11/16"
			67	-6	2.4	8800	890	7.9			40	P-F 7.5		
			135	-9	6	5000	1640	8.2			120			
			157	-10.5	8	4800	1700	8.2			195			
\$4.50														
UX 171	5	.5	22	0	4	3500	850	3	80		60	G-F 6.8		
			45	-5	6							G-P 9.5	1 13/16"	4 11/16"
			67	-12	7						320			
			90	-16.5	11	2500	1200	3			110	P-F 6.5		
			135	-27	16	2200	1320	2.9			350			
			180	-40.5	20	2100	1380	2.9			700			
\$4.50														
UX 210	6	1.1	90	-4.5	3	9700	775	7.5	500	18	240	G-F 7		
			135	-9	5	8000	940	7.5		64	600	G-P 8	2 3/16"	5 5/8"
			180	-10	7	7000	1070	7.5		145	1100	P-F 7		
	7.5	1.25	250	-18	12	5600	1340	7.5		340	2700			
			350	-25	18	5100	1460	7.6		950	5500			
			425	-35	20	5000	1540	7.7		1500	7500			
\$9.00														
DWG. NO. 17 GENERAL RADIO CO. CAMBRIDGE MASS.														
UX 200A	5	.25	22		1.2	35000	570	20					1 13/16"	4 11/16"
			45		1.5	30000	670	20						
\$4.00														
N (215 A)	1	.25										G-F 4.4	5"	2 1/2"
			67	-6	1	20000	300	6		8	40	G-P 4.2		
												P-F 3.8		
V (102 D)	2	.97											2 3/8"	4 1/2"
			130	-1.5	.75	60000	500	30		4.2	50			
L (216 A)	5-6	1											2 3/8"	4 1/2"
			130	-9	8	6000	980	5.9		60	600			
E (205 D)	4.5	1.6											2 3/8"	4 1/2"
			350	-22.5	33	3500	2000	7		890	8000			

For those who are keeping a continuous file of the various issues of the "Experimenter" and who would like a copy of the Tube Data Table to mount on a piece of stiff cardboard for handy reference, we have extra copies which we will be glad to send on request.



IET LABS, INC in the GenRad tradition

534 Main Street, Westbury, NY 11590

www.ietlabs.com

TEL: (516) 334-5959 • (800) 899-8438 • FAX: (516) 334-5988